

| TYPE | OUTPUT | | POLE | TIME RATING | VOLTAGE V | Hz | SYN.SPEED R.P.M |
|--------|--------|-------|------|-------------|-----------|----|-----------------|
| | HP. | kW. | | | | | |
| AEEAGD | 150 | 111.9 | 4 | CONT. | 380 | 50 | 1500 |

TOTALLY ENCLOSED FAN-COOLED TYPE, SQUIRREL-CAGE ROTOR

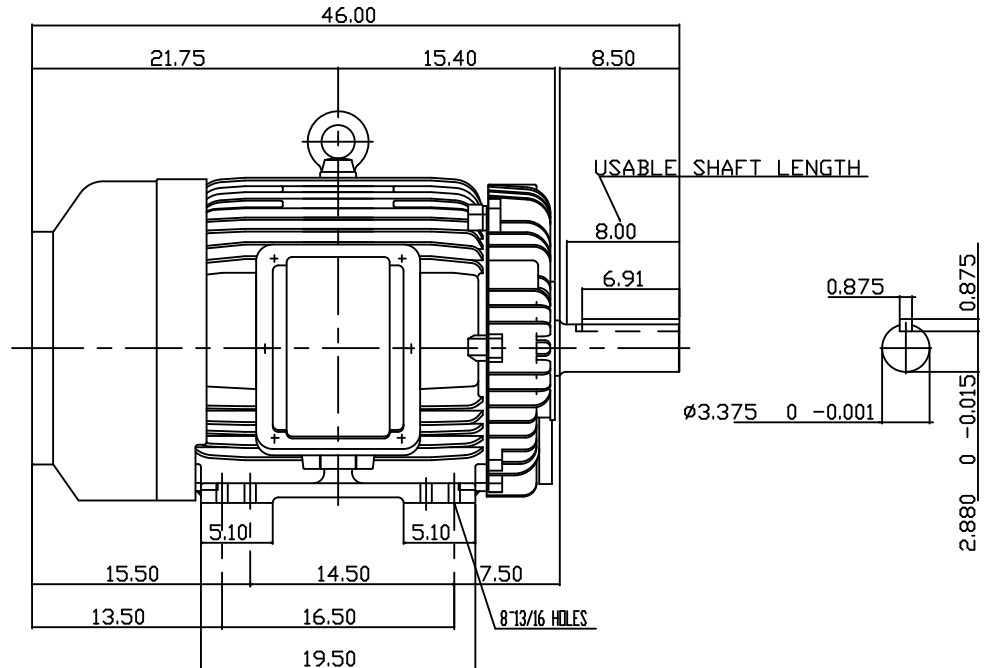
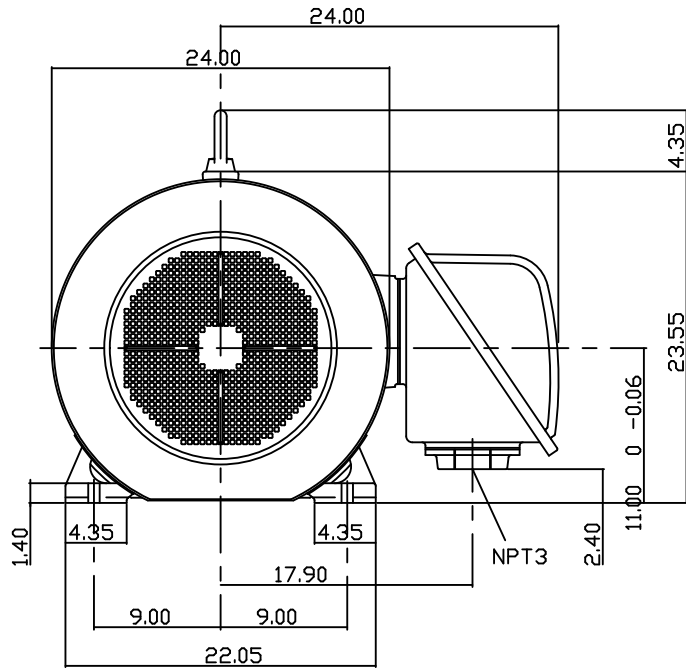

NOTE:

1. DIMENSIONS IN INCH
2. FRAME NO. 445T
3. F CLASS INSULATION, S.F.1.0
4. FOR BELT DRIVE
5. ENCLOSURE: IP54
6. BEARING SIZE DRIVE END: NU318C3
NON-DRIVE END: 6316
7. APPROX. WEIGHT: 1900 LBS

TW-56C

| | |
|-------------------|-------------------------|
| DATE 20110905 | OUTLINE DIMENSIONS |
| CAT. # CD1504R-50 | 3-PHASE INDUCTION MOTOR |
| DWG NO. 3B040C063 | REV: 00 |

| | | |
|-------|---------|--------------|
| DWN. | T.H.Pan | JUN '30 2005 |
| CHKD. | H.HUANG | JUN '30 2005 |
| APPD. | C.WANG | JUN '30 2005 |

TEC Westinghouse