

TYPE	OUTPUT		POLE	TIME RATING	VOLTAGE V	Hz	SYN.SPEED R.P.M
	HP.	kW.					
AEEAGD	125	93.3	6	CONT.	190/380	50	1000

TOTALLY ENCLOSED FAN-COOLED TYPE, SQUIRREL-CAGE ROTOR

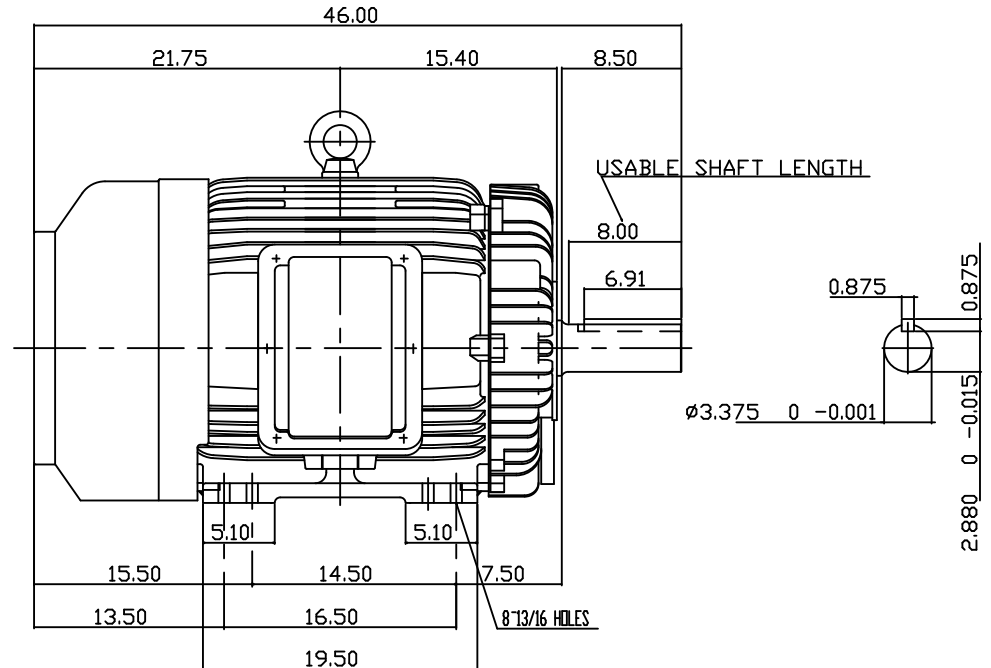
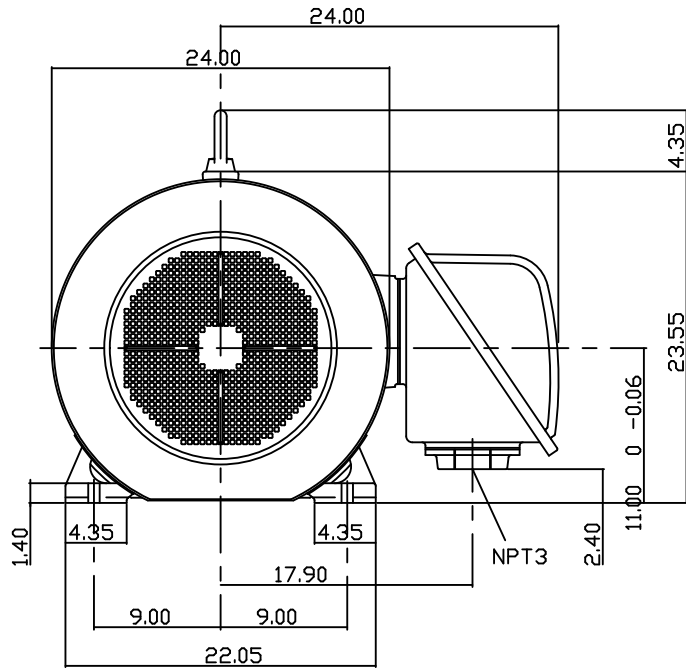

NOTE:

1. DIMENSIONS IN INCH
2. FRAME NO. 445T
3. F CLASS INSULATION, S.F.1.0
4. FOR BELT DRIVE
5. ENCLOSURE: IP54
6. BEARING SIZE DRIVE END: NU318C3  
NON-DRIVE END: 6316
7. APPROX. WEIGHT: 1900 LBS

TW-56C

DATE 20110905	OUTLINE DIMENSIONS
CAT. # CD1256R-50	3-PHASE INDUCTION MOTOR
DWN. T.H.Pan JUN '30 2005	DWG NO. REV: 00
CHKD. H.HUANG JUN '30 2005	3B040C063
APPD. C.WANG JUN '30 2005	

