

DATE
Sept. 6, 2011
CAT. #: CD0754R-50

OUTLINE DIMENSIONS
3-PHASE INDUCTION MOTOR

MOTOR TYPE:
AEEAGD
FRAME NO. 365T

Pole	HP	kW	Hz	VOLT	Syn. Speed r/min(rpm)
4	75	55.95	50	190/380	1500

Ins	Rating	Dimension in	Approx Weight	Bearings
F	CONT.	inches	823 lbs.	DE: NU313 NDE: 6213

Totally Enclosed Fan-Cooled Type. Squirrel-Cage Rotor.

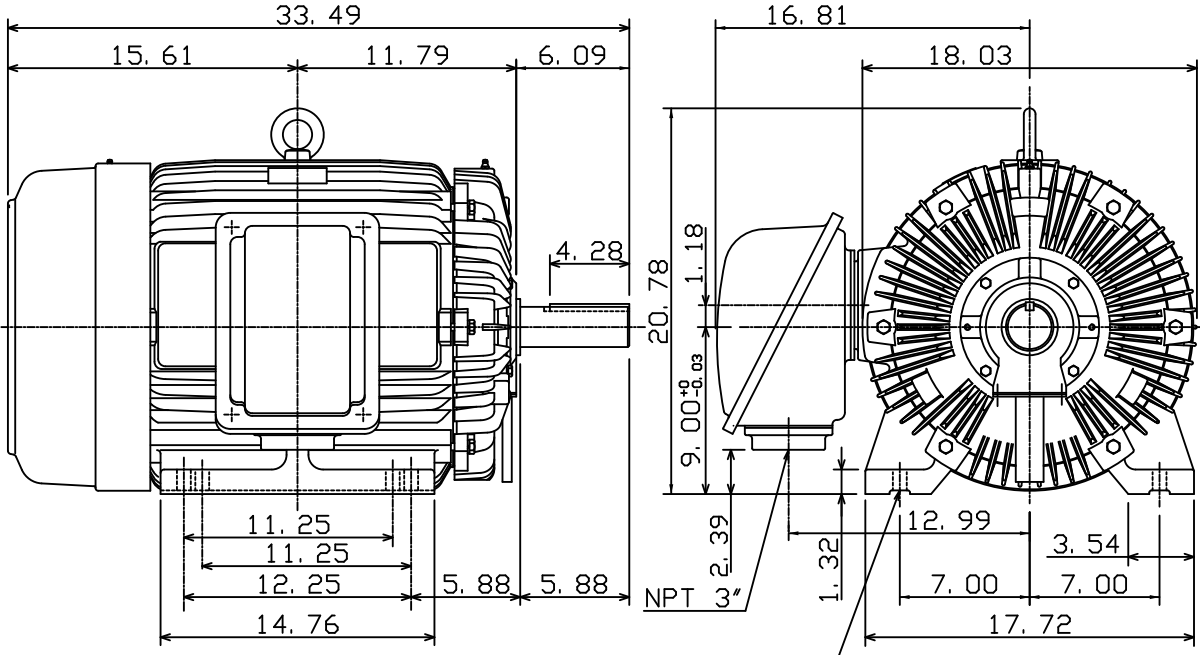

8-∅0.66 Holes

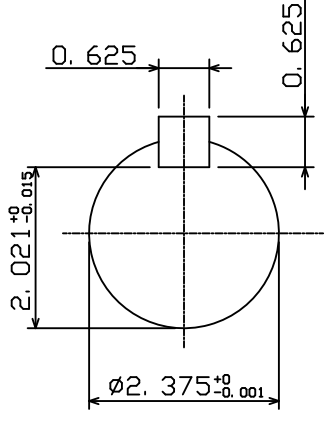

◇		
---	--	--

DWN.	K. L. KUO	01-05-05
CHKD.	C. H. KAO	01-28-05
APPD.	M. C. TSAI	01-28-05



DWG NO.
31049J361490