

| | | | | | |
|-----------------------|--|---|--|-----------------------|--|
| CATALOG NO. CD0254 | | OUTLINE DIMENSIONS 3-PHASE INDUCTION MOTOR | | MOTOR TYPE: AEEAGD | |
| DATE JULY-12-15 | | | | FRAME NO. 284T | |

| | | | | | |
|------|----|----|----|---------|------------|
| Pole | HP | kW | Hz | VOLT | r/min(rpm) |
| 4 | 25 | 19 | 60 | 230/460 | 1800 |

| | | | | | |
|-----|--------|--------------|---------------|-----------|------------|
| Ins | Rating | Dimension in | Approx Weight | Bearings | |
| F | CONT. | inches | 378 lbs. | DE: 6311Z | NDE: 6310Z |

Totally Enclosed Fan-Cooled Type, Squirrel-cage Rotor.

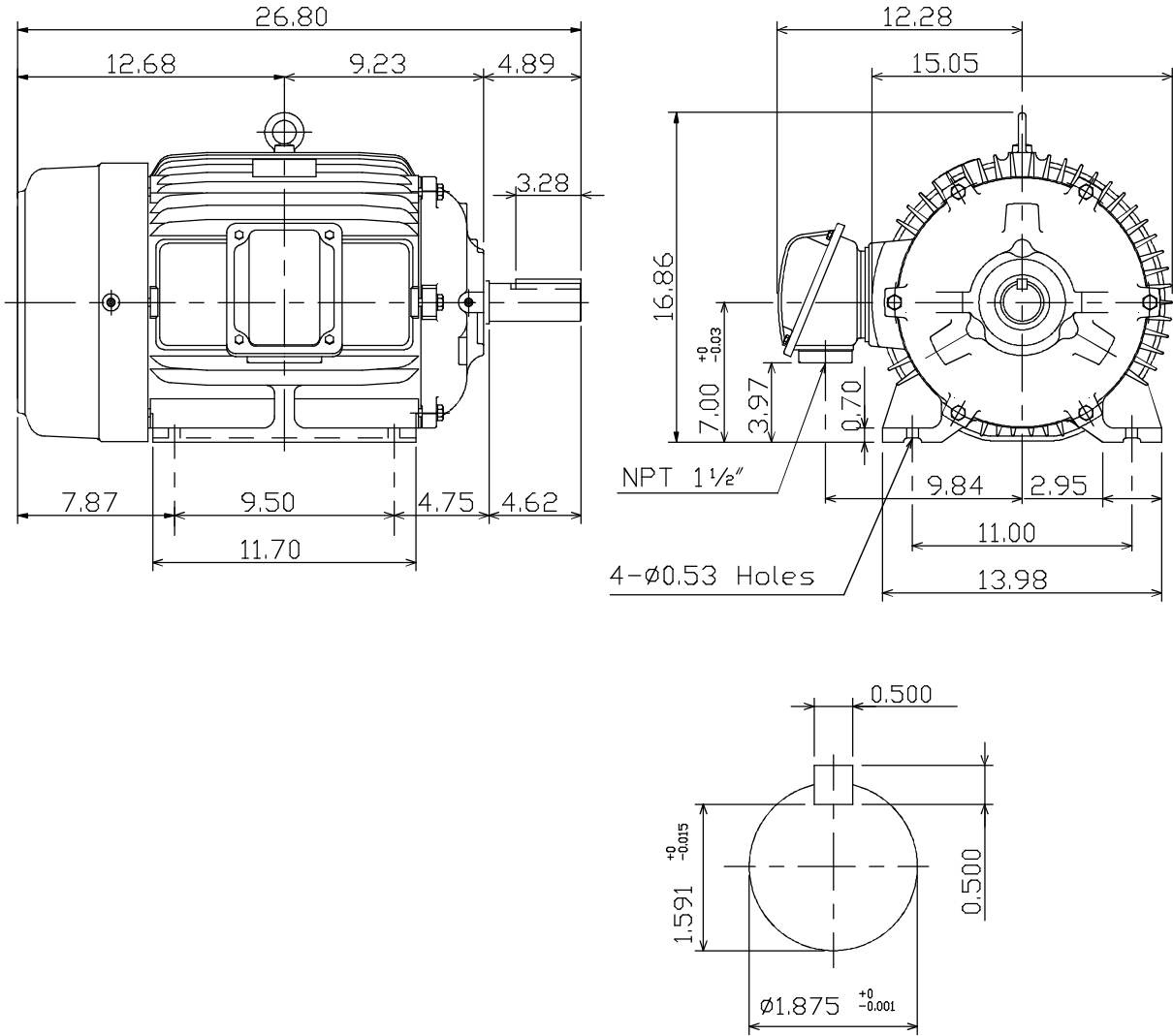

- NOTE:
1. ENCLOSURE: IP55
 2. SHAFT MATERIAL: SCM440 Q&T (AISI 4140 EQUIV)
 3. WITH THERMISTOR: PTC 140°C x 3PCS
WIRED IN MAIN TERMINAL BOX

TW-26C

| | | |
|---|-------------|----------|
| ◇ | DWG. C. RAM | 07 12 15 |
|---|-------------|----------|

| | | | | |
|-------|-----------|----------|--|--------------|
| DWG. | W.J.HUANG | 06.18.13 | TEC   Westinghouse | DWG NO. |
| CHKD. | K.L.KUD | 06.20.13 | | 31057H212590 |
| APPD. | C.H.SHYU | 06.20.13 | | |